

VHLD SERIES

C.S.I. Section 11420

SUPER STEAMER, DIRECT STEAM

TWO OR THREE COMPARTMENT MODELS



(Shown on optional cabinet base)



SPECIFICATIONS:

Direct steam, Super Steamer, Vulcan-Hart Model No. (VHL2D) (VHL3D). 6 psi pressure steam cooker. Cooker body is 8 gauge satin finish type 304 stainless steel exterior. Doors have a removable aluminum alloy inner liner with full perimeter gasket and sealed by turning a "T" type handle. The door cannot be opened while the steamer is on. Automatic timed compartment controls with 60 minute timer (add suffix "S" to model number). Lift out stainless steel wire Adapt-A-Pan™ supports eight 2½", six 4", or four 6" deep food pans (one for 2 compartments)(two for 3 compartments) and one manual pull out shelf. Cooker mounted on a 2" diameter welded stainless steel tubing leg stand with 6" adjustable flanged feet, for floor anchoring. Direct steam supply at 10 to 50 PSI with a flow of (2 compts., 80 lbs. steam/hr.) (3 compts., 115 lbs. steam/hr.).

Exterior dimensions:

VHL2D: 36"w x 33"d x 58"h (61"h with cabinet base).

VHL3D: 36"w x 33"d x 66"h (76"h with cabinet base).

U L listed. Classified by U L to NSF Std. #4.

- VHL2D (S) (P) 2 compartments
- VHL3D (S) (P) 3 compartments

STANDARD FEATURES

- Direct steam supply at 10 to 50 PSI with a flow of (2 compt. - 80 lbs. steam/hr.) (3 compt. - 115 lbs. steam/hr.)
- 6 psi pressure steam cooker.
- Cooker body is 8 gauge satin finish type 304 stainless steel exterior. Doors have a removable aluminum alloy inner liner with full perimeter gasket and sealed by turning a "T" type handle. The door cannot be opened when steamer is on.
- Automatic timed compartment controls with 60 minute timer. (Add suffix "S" to model number.)
- Lift out stainless steel wire Adapt-A-Pan™ supports eight 2½", six 4" or four 6" deep food pans (one for 2 compartments)(two for 3 compartments) and one manual pull out shelf.
- Cooker mounted on a 2" diameter welded stainless steel tubing leg stand with 6" adjustable flanged feet for floor anchoring.
- One year limited parts and labor warranty.

OPTIONS

- 28" high cabinet with stainless steel front full height doors, slip-off stainless steel side and aluminized rear panel with 6" adjustable legs with flanged feet for anchoring.
- Pre-Vent™, automatic load compensated timed, combination pressure and free venting cooking with automatic exhaust. (Add suffix "P" to model number).
- Correction package:
 - a. Cabinet door with hasp (lock by others).
 - b. Security type tamper resistant fasteners.
 - c. Control cover (lock by others).
- Control circuit step down transformer to 120V, if higher than 120 volt.
- Second year extended limited parts and labor warranty.

ACCESSORIES

- Stainless steel back panel.
- Manual sliding shelf (Qty. ____).
- Removable 12 x x20 sliding shelf (Qty. ____).
- Adapt-A-Pan™ support (Qty. ____).



VHLD SERIES

SUPER STEAMER, DIRECT STEAM

TWO OR THREE COMPARTMENT MODELS

PAN CAPACITIES (Per compartment)

MODEL	2 1/2" deep	4" deep	6" deep	18" x 26"
VHLD	8	6	4	6

NOTE:

- Dimensions which locate the above connections have a tolerance of + or -3" (+ or -75 mm).
- Installation of backflow preventers, vacuum breakers and other specific code requirements is the responsibility of the owner and installer. It is the responsibility of the owner and installer to comply with local codes.
- Plastic drains are not recommended due to inherent limited temperatures of the plastic. Boiler purge temperatures may exceed 180°F. The installer may be required to provide means to reduce boiler purge water temperature to be that of the condensate temperature of 140°F or less.
- This appliance is manufactured for commercial installation only and is not intended for home use.

SERVICE CONNECTIONS:

- Steam Supply:** 3/4" NPT for 10 - 50 psi direct steam.
- Electric Connection for Controls:** 120/60/1, 300 watt maximum power supply with grounding wire required. (For other than 120 volt supply, consult factory for location of this connection.)
- Drain:** Condenser box, compartment and boiler, 2" NPT. (Provide an open air gap type drain within 12" of condenser box and for best results at a distance so that steam vapors will not enter the steamer from underneath the control area. Do not connect solidly to any drain connection.)

EQUIPMENT CLEARANCE:

Rear: 6" Right and left side: 6"

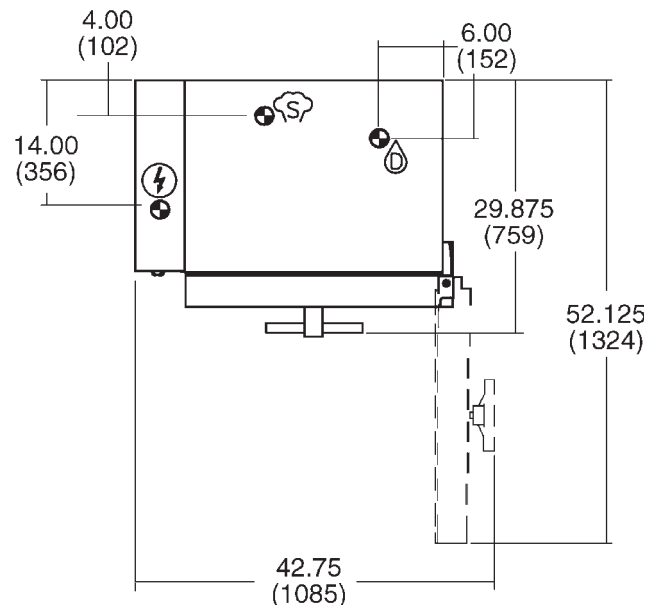
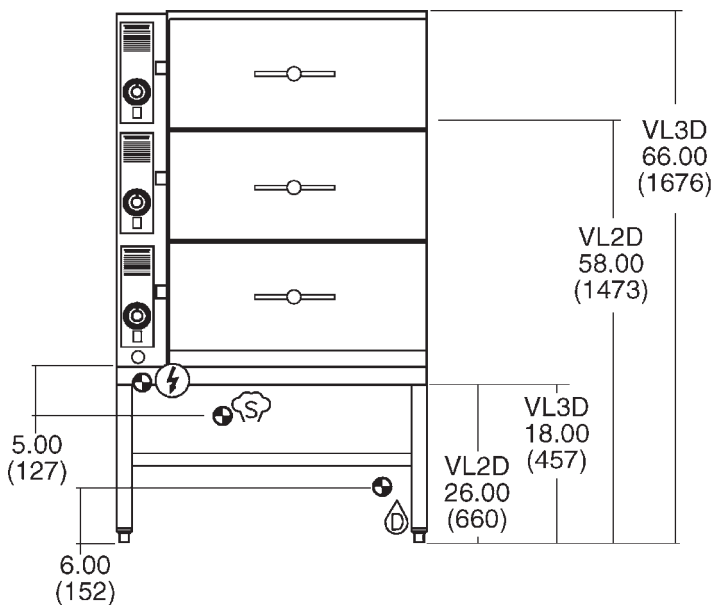

NOTE: In line with its policy to continually improve its products, Vulcan-Hart Company reserves the right to change materials and specifications without notice.