



**TRUE FOOD SERVICE EQUIPMENT, INC.**

2001 East Terra Lane • P.O. Box 970 • O'Fallon, Missouri 63366  
 (636)240-2400 • FAX (636)272-2408 • (800)325-6152 • www.truemfg.com  
 Parts Dept. (800)424-TRUE • Parts Dept. FAX# (636)272-9471

Project Name: \_\_\_\_\_

Location: \_\_\_\_\_

Item #: \_\_\_\_\_ Qty: \_\_\_\_\_

Model #: \_\_\_\_\_

A/A #

S/S #

Model:  
**TPP-60D-2**

**Pizza Prep Table:**  
*Solid Door and Drawered Refrigerator*

**TPP-60D-2**



- ▶ True's pizza prep tables are designed with enduring quality that protects your long term investment.
- ▶ Oversized, environmentally friendly (R134A) forced-air refrigeration system holds 33°F to 41°F (.5°C to 5°C).
- ▶ Complies with and listed under ANSI/NSF-7-1997-6.3.
- ▶ All stainless steel front, top and cabinet ends. Matching aluminum finished back.
- ▶ Stainless steel, patented, foam insulated flat lids keep pans' temperature colder, lock in freshness, and minimize condensation.
- ▶ Extra-deep 19 1/2" (496 mm) full length removable cutting board included. Sanitary, high-density, NSF approved white polyethylene provides tough preparation surface.
- ▶ Foamed-in-place, high density polyurethane insulation (CFC free).
- ▶ Heavy duty PVC coated wire shelves.
- ▶ Each drawer accommodates (2) 12" L x 20" W x 8" D (305 mm x 508 mm x 204 mm) pans (sold separately).

**ROUGH-IN DATA**

Chart dimensions rounded up to the nearest 1/8" (millimeters rounded up to next whole number). Specifications subject to change without notice.

Model	Doors/ Drawers	Capacity (Cu. Ft.) (liters)	Shelves	Pans (top)	Cabinet Dimensions (inches) (mm)			HP	Voltage	Amps	NEMA Config.	Cord Length (total ft.) (total m)	Crated Weight (lbs.) (kg)
					L**	D†	H*						
TPP-60D-2	1/2	15.9 451	2	8	60 1/4	32 1/4	35 3/4	1/3	115/60/1 230-240/50/1	7.9 4.2	5-15P ▲	7 2.13	420 191
					1531	820	909	1/3					

\*\* Length does not include 3/8" (10 mm) each side for lid pins and 1/4" (7 mm) each side for cutting board brackets and thumb screws.

† Depth does not include 1" (26 mm) for rear bumpers and 3" (77 mm) for cutting board.

\* Height does not include 6 1/4" (159 mm) for castors or 6" (153 mm) for optional legs.

▲ Plug type varies by country.

	<b>APPROVALS:</b>  	<b>AVAILABLE AT:</b>  
4/06 Printed in U.S.A.		

Model:  
**TPP-60D-2**

**Pizza Prep Table:**  
Solid Door and Drawered Refrigerator



## STANDARD FEATURES

### DESIGN

- True's commitment to using the highest quality materials and oversized refrigeration systems provides the user with colder product temperatures, lower utility costs, exceptional food safety and the best value in today's food service marketplace.

### REFRIGERATION SYSTEM

- Factory engineered, self-contained capillary tube system using environmentally friendly (CFC free) R134A refrigerant.
- Oversized, factory balanced refrigeration system with guided airflow to provide uniform temperature in food pan rail and cabinet interior.
- Forced-air design holds 33°F to 41°F (.5°C to 5°C) product temperature in food pans and cabinet interior. Complies with and listed under ANSI/NSF-7-1997-6.3.
- Condensing unit accessed from front behind removable panel on right hand side of cabinet, slides out for easy maintenance.

### CABINET CONSTRUCTION

- Exterior - stainless steel front, top and cabinet ends. Matching aluminum finished back.
- Interior - attractive, NSF approved, white aluminum liner. 300 series stainless floor with coved corners.
- Insulation - entire cabinet structure, solid door, and drawer facings are foamed-in-place using high density, CFC free, polyurethane insulation.
- 5" (127 mm) diameter stem castors. 36" (915 mm) work surface height.

### DOOR/DRAWERS

- Door and drawers have stainless steel exterior with white aluminum liner to match cabinet interior.
- Door swings within cabinet dimensions.
- Heavy duty all stainless steel drawer slides.
- Each door and drawer fitted with 12" (305 mm) long recessed handle that is foamed-in-place with a sheet metal interlock to insure permanent attachment.
- Magnetic door/drawer gaskets of one piece construction, removable without tools for ease of cleaning.

### SHELVING

- Two (2) adjustable, heavy duty PVC coated wire shelves 17<sup>1</sup>/<sub>4</sub>" L x 28" D (439 mm x 712 mm). Four (4) chrome plated shelf clips included per shelf.
- Shelf support pilasters made of same material as cabinet interior; shelves are adjustable on 1/2" (13 mm) increments.

### DRAWER PAN CAPACITY

- Each drawer accommodates two (2) 12" L x 20" W x 8" D (305 mm x 508 mm x 204 mm) food pans (sold separately). Drawers will support varying pan configurations with pan dividers bars (drawer pans and divider bars optional).

### MODEL FEATURES

- Evaporator is epoxy coated to eliminate the potential of corrosion.
- Extra-deep 19<sup>1</sup>/<sub>2</sub>" (496 mm) full length removable cutting board included. Sanitary, high-density, NSF approved white polyethylene provides tough preparation surface.

- Stainless steel, patented, foam insulated flat lids keep pans' temperature colder, lock in freshness and minimize condensation.
- Refrigerated pan rail comes standard with eight (1/3 size) 12<sup>3</sup>/<sub>4</sub>" L x 6<sup>1</sup>/<sub>4</sub>" W x 6" D (324 mm x 159 mm x 153 mm) NSF approved clear polycarbonate insert pans.
- NFS-7 compliant for open food product.

### ELECTRICAL

- Unit completely pre-wired at factory and ready for final connection to a 115/60/1 phase - 15 amp dedicated outlet. Cord and plug set included.



115/60/1  
NEMA-5-15R

### OPTIONAL FEATURES/ACCESSORIES

Upcharge and lead times may apply.

- 230 - 240V / 50 Hz.
- 6" (153 mm) standard legs.
- 6" (153 mm) seismic/flanged legs.
- Garnish rack.
- Pizza prep service shelf.
- Single utility shelf.
- Double utility shelf.
- 19<sup>1</sup>/<sub>2</sub>" (496 mm) deep, 1/2" (13 mm) thick, white polyethylene cutting board.
- 19<sup>1</sup>/<sub>2</sub>" (496 mm) deep, 1/2" (13 mm) thick, composite cutting board.
- Pan dividers.
- Remote cabinets (condensing unit supplied by others; system comes standard with 404A expansion valve and requires R404A refrigerant), consult factory technical service department for BTU information.

## PLAN VIEW

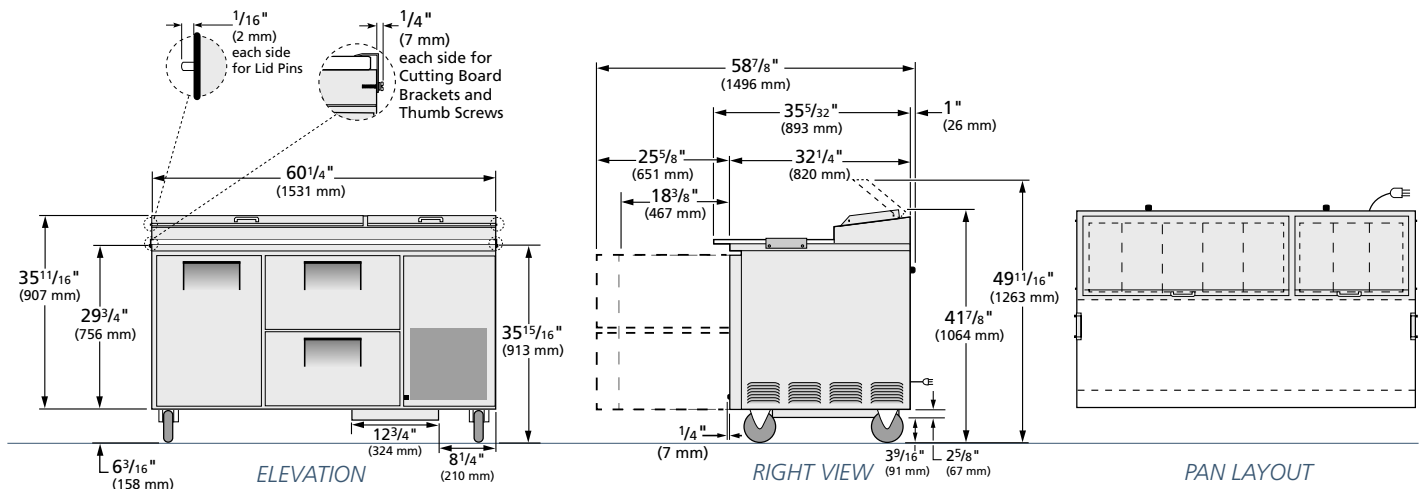

### WARRANTY

One year warranty on all parts and labor and an additional 4 year warranty on compressor. (U.S.A. only)

METRIC DIMENSIONS ROUNDED UP TO THE NEAREST WHOLE MILLIMETER

SPECIFICATIONS SUBJECT TO CHANGE WITHOUT NOTICE



Model	Elevation	Right	Plan	3D
TPP-60D-2	TFQY72E	TFQY43S	TFQY72P	TFQY723

## TRUE FOOD SERVICE EQUIPMENT

2001 East Terra Lane • P.O. Box 970 • O'Fallon, Missouri 63366 • (636)240-2400 • FAX (636)272-2408 • (800)325-6152 • www.truemfg.com